

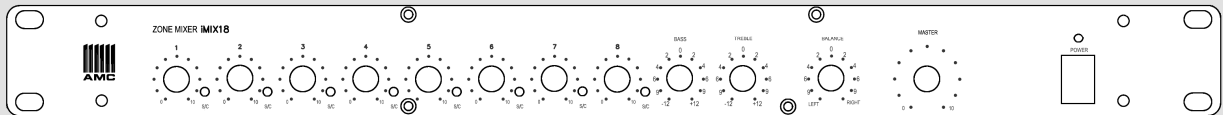

iMIX 18

Preamplifier



User Manual

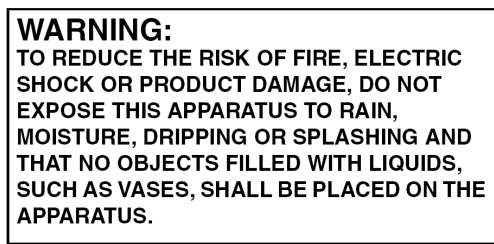
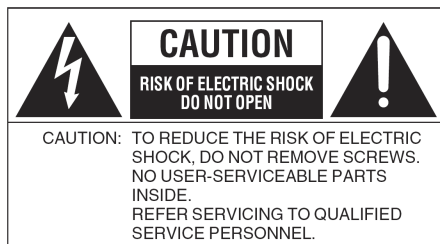

IMPORTANT SAFETY INSTRUCTIONS

When using this electronic device, basic precautions should always be taken, including the following:

1. Read all instructions before using the product.
2. Do not use this product near water (e.g., near a bathtub, washbowl, kitchen sink, in a wet basement or near a swimming pool etc).
3. Use this device when you are sure that preamplifier has a stable horizontal base and it is fixed securely.
4. This product, in combination with amplifier and loudspeakers may be capable of producing sound levels that could cause permanent hearing loss. Do not operate for a long period of time at a high volume level or at a level that is uncomfortable. If you experience any hearing loss or ringing in the ears, you should consult with otorhinolaryngologists. The product should be positioned so that proper ventilation is maintained.
5. The product should be located away from heat sources such as radiators, heat vents, or other devices (including amplifiers) that produce heat.
6. The product should be connected to a power supply that is described in the operating instructions or are marked on the product. Replace the fuse only with one of the specified type, size and correct rating.
7. The power supply cord should be undamaged and never share an outlet or extension cord with other devices so that the outlet or extension cord's power rating is exceeded. Never leave device plugged be left plugged in to the outlet when it's not being used for a long period of time.
8. Care should be taken so that objects do not fall into, and liquids would not be spilled through, the enclosure's openings.
9. The product should be serviced by qualified service personnel if:
 - The power supply cord or the plug has been damaged.
 - Objects have fallen into or liquid has been spilled on the product.
 - The product has been exposed to rain.
 - The product has been dropped or the enclosure damaged.

All the other servicing must be referred to qualified service personnel too.
10. Unplug this device when unused for long periods of time.
11. There are some areas with high voltage inside, to reduce the risk of electric shock do not remove cover of the preamplifier. The cover should be removed by the qualified personnel only. **No user serviceable parts inside.**

CONTENTS:

<u>Before you start</u>	
What's in the box	4
Features	4
Hints on installation	4
<u>Controls and connections</u>	
Front panel	5
Rear panel	6
Connectors	7
Cable wiring examples	7
Application example	10
<u>Specifications</u>	
Specifications	11

4 Before you start

Congratulations on your choice of an **iMIX 18** preamplifier. **iMIX 18** is a professional mixer preamplifier, with built-in eight balanced XLR inputs and two stereo RCA inputs. Input gain selector for the balanced inputs, phantom power, signal and clip indication and balanced XLR stereo output are collected in to this device, to make **iMIX 18** more flexible and easy adapted to various of installations. Please read this manual carefully to get the most important information about your new unit. Thank you for selecting **iMIX 18**.

What's in the box?

Items those are included in the box:

- Preamplifier **iMIX 18**
- Instruction manual
- Power cable

Features

- Six balanced inputs with selectable gain, Line or Mic. Two microphone inputs. Two stereo RCA inputs in parallel to microphone XLR.
- Phantom power. Switchable on each XLR inputs separately.
- Priority input with priority on/off switch.
- Signal and input clip indication.
- 2 Band: low and high equalizer.

Hints on Installation

This user manual contains an important information on operating **iMIX18** preamplifier correctly and safety. Please read it carefully before operating your preamplifier.

Before connecting microphones or instruments, make sure that the power of all your systems components including the preamplifier is turned off. Also, make sure that all inputs controls of your preamplifier are turned down. This will avoid damage to your speakers and avoid unexpected noise. Before disconnecting the **iMIX18** always turn off the power switch.

Front Panel

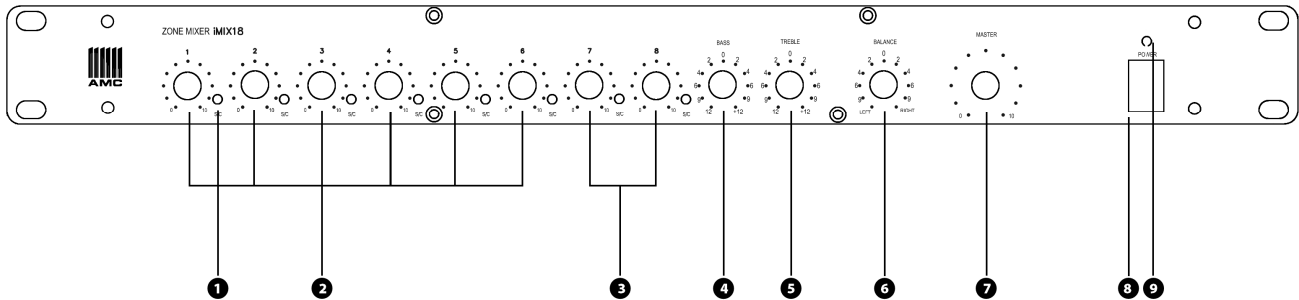

1. INDICATION

These LED's indicate audio signal status in the preamplifier input. LED lights in green when audio signal in the input reach (-16dBu/-50dBu)* level, when the signal level became too high (+12dBu/-22dBu)* and the input starts clipping LED lights in red.

2. VOLUME OF BALANCED XLR INPUTS

These rotary knobs are for adjusting volume level of the universal mono inputs. First six inputs can be used as line level as well as microphone level inputs. The input gain selector is located in the rear panel. The phantom power can be activated for these inputs separately in rear panel too. The first input can be set as priority input by using priority switch located in the rear panel.

3. VOLUME FOR STEREO INPUTS

These rotary knobs are for adjusting volume level of the line level stereo RCA inputs which are in parallel with microphone level XLR.

4. LOW TONE CONTROL

This knob is used to attenuate a low tone of the sound. Low frequency can be adjusted in ± 12 dB range.

5. HIGH TONE CONTROL

This knob is used to attenuate a high tone of the sound. High frequency can be adjusted in ± 12 dB range.

6. BALANCE CONTROL

This knob is used to attenuate a volume level proposal between the left and right outputs.

7. MASTER

This potentiometer is designed to adjust audio level in the master output.

8. POWER BUTTON

This button is designed to turn on/off main power of the device.

9. "POWER ON" INDICATOR

This LED indicates status of the power. This LED indicates when preamplifier is turned on.

(-16dBu/-50dBu)* -16dBu when input gain switch is set to "LINE" position. -50dBu when input gain switch is set to "MIC" position.

(+12dBu/-22dBu)* +12dBu when input gain switch is set to "LINE" position. -22dBu when input gain switch is set to "MIC" position.

Rear Panel

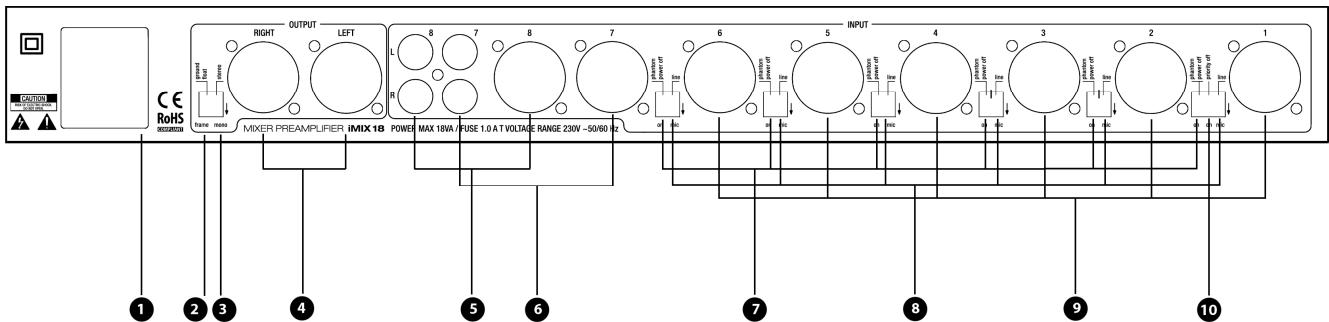

1. FUSE HOLDER AND MAIN POWER CONNECTOR

Use T1A 250V fuse only. Contact with qualified service if fuse blows up constantly. The connector is used to connect the AC 220V – 240V ~50Hz power to preamplifier.

2. GROUND LIFT SWITCH

Ground lift switch is used to eliminate or reduce noise caused by ground loops.

3. MONO STEREO SWITCH

To merge both left and right outputs into one set this switch to mono position, to make this outputs independent from each other, set switch to stereo.

4. MASTER OUTPUT

This is balanced, line level output, XLR connectors.

5. XLR/RCA INPUT

This input composes from microphone level balanced XLR and stereo line level RCA. The phantom power for this input is unavailable and the gain of RCA and XLR is fixed.

6. XLR/RCA INPUT

This input composes from microphone level balanced XLR and stereo line level RCA. The phantom power for this input is unavailable and the gain of RCA and XLR is fixed.

7. PHANTOM POWER SWITCH

Set phantom power switch to "ON" position to activate phantom power to desired input. Maximum phantom power voltage +40V. The maximum current per input is 5mA. The phantom power switch is independent from the gain switch, so please disable phantom power if you want to set line level gain after using condenser microphone. To disable phantom power set switch to "phantom power off" position.

8. LINE/MIC SWITCH

This is input's gain selector. Set switch to "line" position to adapt input gain for line level equipment and set to "mic" for microphones. Input gain when "line" level is selected - 6dBu, when "mic" level is selected - 40dBu.

9. BALANCED XLR INPUTS

These are universal balanced XLR inputs. The gain and phantom power for these inputs are selected by using LINE/MIC switches located in the rear panel near to XLR connectors.

10. PRIORITY

Input 1 can set as priority input. To activate the priority, please set priority switch to „on" position. To deactivate set to priority „off" position.

Connectors

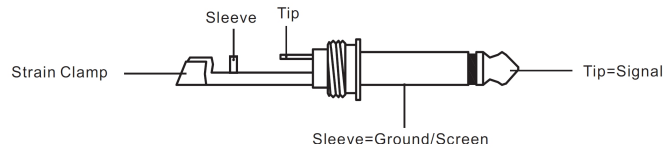

TR connector

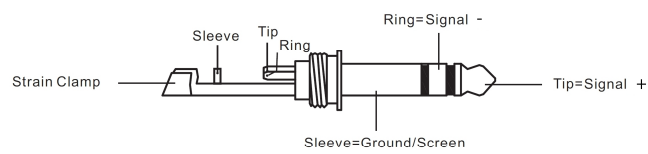

TRS connector

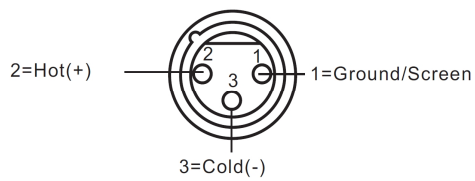

XLR male connector

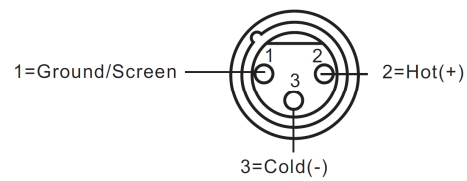

XLR female connector

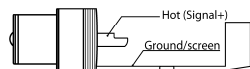

RCA connector

Cable wiring examples



Cable to balanced input from balanced output. TRS connectors.



Cable to unbalanced input from balanced output. TRS and TS connectors.



Cable to balanced input from unbalanced output. TS and TRS connectors.



Cable to unbalanced input from unbalanced output. TS connectors.

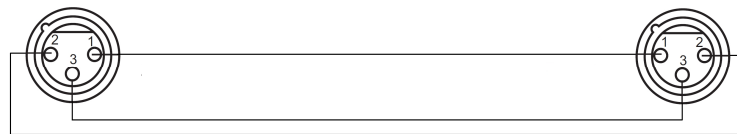

Cable to balanced input from balanced output. XLR connectors.

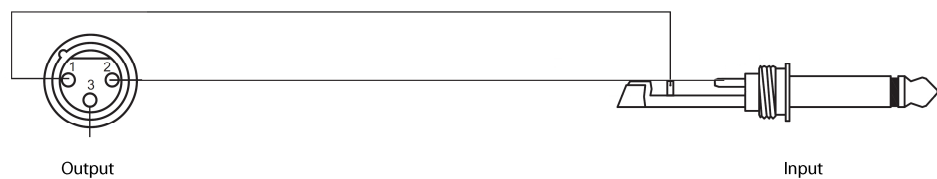

Cable to unbalanced input from balanced output. XLR and TS connectors.

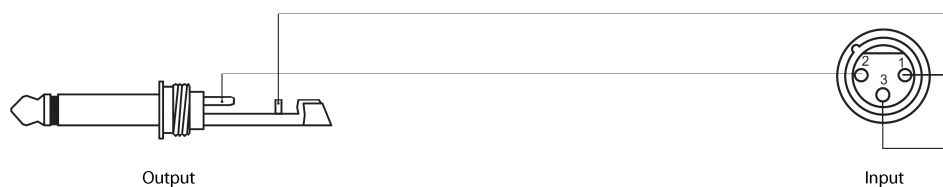

Cable to balanced input from unbalanced output. TS and XLR connectors.

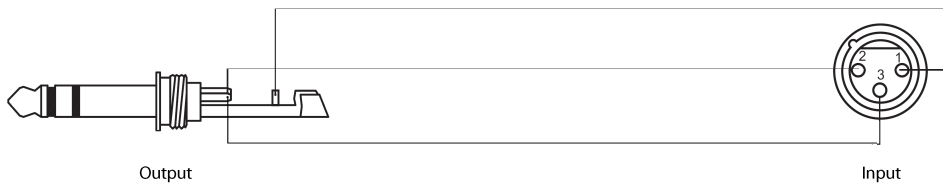

Cable to balanced input from balanced output. TRS and XLR connectors.



RCA cable.



Cable to unbalanced input from RCA output. RCA and TS connectors.

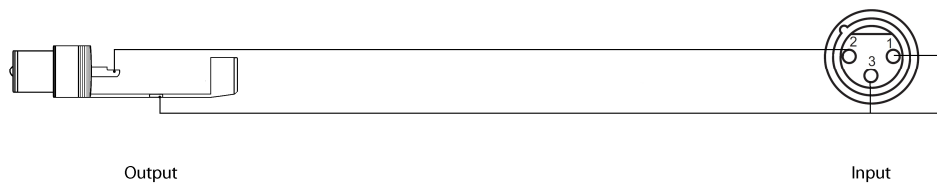

Cable to balanced input from RCA output. RCA and XLR connectors.

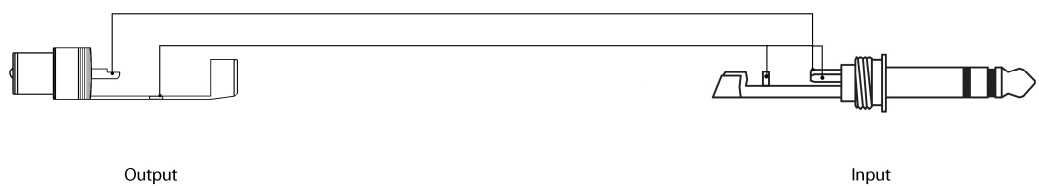

Cable to balanced input from RCA output. RCA and TRS connectors.



Cable to RCA input from balanced output. RCA and XLR connectors.

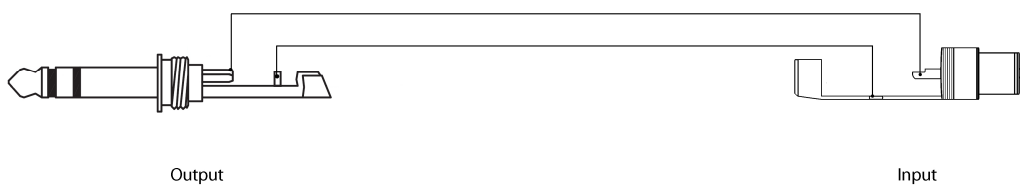

Cable to RCA input from balanced output. RCA and TRS connectors.

Application example

Background music station with paging microphone priority:

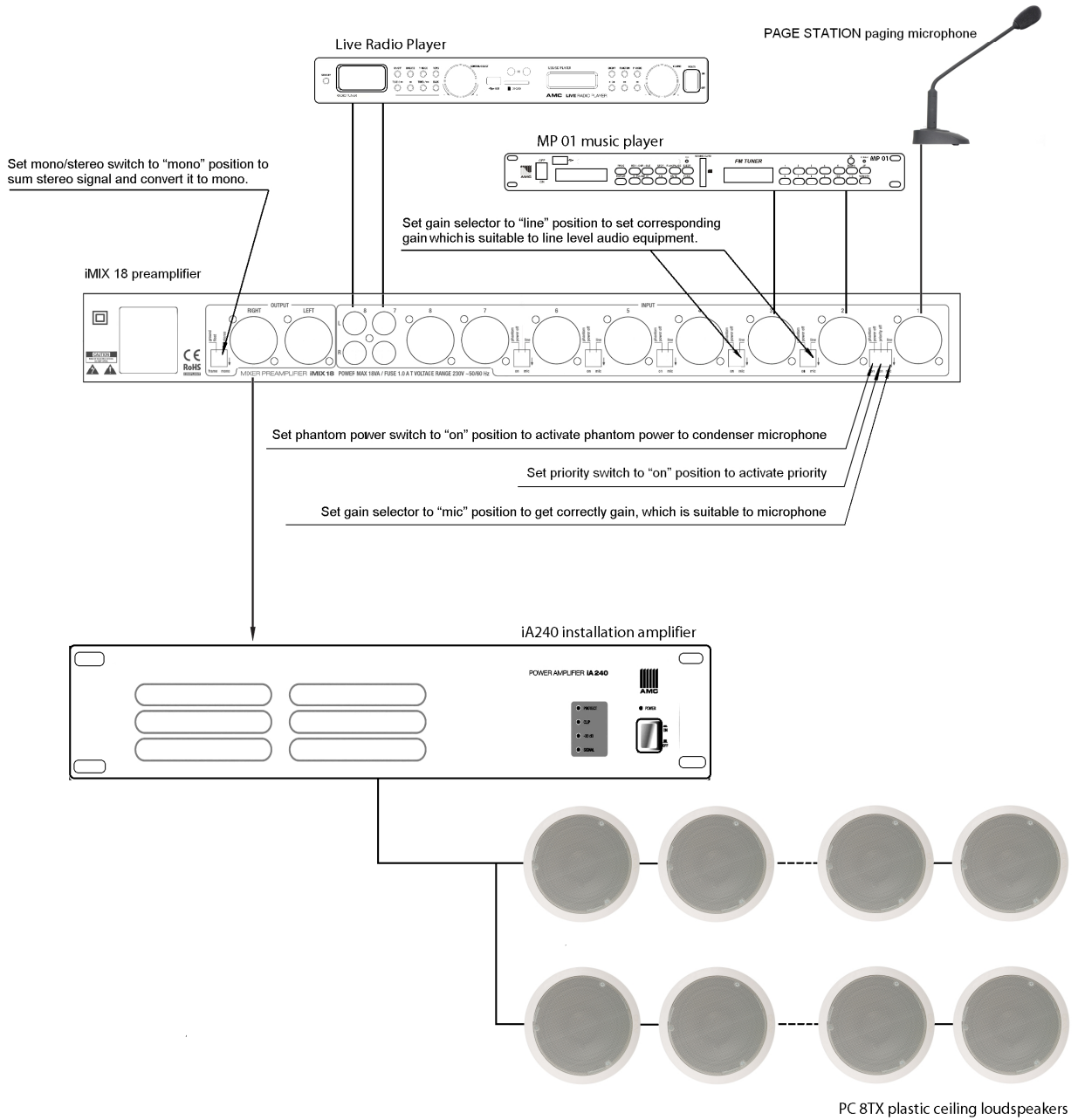

Specifications

Power supply	AC 230V, 50Hz
AC power consumption	8,8W
Phantom power voltage	40V (max.)
BALANCED input gain (line level) Maximum input level	-6 dBu +10dBu
BALANCED input gain (Mic level) Maximum input level	- 40dBu -24dBu
RCA input gain Maximum input level	-2dBu +16dBu
Maximum MAIN output level	+15dBu
THD SN ratio Crosstalk (input to output) Separation between stereo channels	0,3% (1Khz) >86dBu -71dBu -30dBu
Microphone input impedance Line input impedance Output impedance	20k Ω 20k Ω 75 Ω
Frequency response Equalization (low) Equalization (High)	20 Hz – 22 KHz \pm 12 dBu \pm 15 dBu
Dimensions Weight	483mm x 205 mm x 44 mm 2,6 kg

The specifications above are correct at the time of printing of this manual. For improvement purposes, all specifications for this unit, including design and appearance, are subject to change without prior notice.

AMC is a registered trademark of AMC Baltic www.amcpro.eu

