



User
Manual

DSP4X6
Digital Signal Processor



Safety instructions

When using this electronic device, basic precautions should always be taken, including the following:

- 1 Read all instructions before using the product.
- 2 Do not use this product near water (e.g., near a bathtub, washbowl, kitchen sink, in a wet basement or near a swimming pool etc). Care should be taken that objects do not fall into liquids and liquids would not be spilled on the device.
- 3 Use this device when you are sure that it has a stable base and it is fixed securely.
- 4 This product may be capable of producing sound levels that could cause permanent hearing loss. Do not operate for a long period of time at a high volume level or at a level that is uncomfortable. If you experience any hearing loss or ringing in the ears, you should consult with otorhinolaryngologist.
- 5 The product should be located away from heat sources such as radiators, heat vents, or other devices that produce heat.
- 6 Note for power connections: for pluggable equipment, the socket-outlet shall be installed near the equipment and shall be easily accessible.
- 7 The power supply should be undamaged and never share an outlet or extension cord with other devices. Never leave device plugged into the outlet when it is not being used for a long period of time.
- 8 Power disconnection: when the power cord connected to the power grid is connected to the machine, the standby power is turned ON. When the power switch is turned ON, the main power is turned ON. The only operation to disconnect the power supply from the grid, unplug the power cord.
- 9 Protective Grounding - An apparatus with class I construction shall be connected to a power outlet socket with a protective grounding connection.
Protective Earthing - An apparatus with class I construction shall be connected to a mains socket outlet with a protective earthing connection.
- 10 The lightning flash with an arrowhead symbol, with an equilateral triangle, is intended to alert the user to the presence of uninsulated dangerous voltage¹ within the products enclosure that may be of sufficient magnitude to constitute a risk of electric shock to persons. 
- 11 The exclamation mark within an equilateral triangle is intended to alert the user to the presence of important operating and maintenance (servicing) instructions in the literature accompanying the appliance. 
- 12 There are some areas with high voltage inside, to reduce the risk of electric shock do not remove cover of the device or power supply. The cover should be removed by the qualified personnel only.
- 13 The product should be serviced by qualified service personnel if:
 - The power supply or the plug has been damaged.
 - Objects have fallen into or liquid has been spilled on the product.
 - The product has been exposed to rain.
 - The product has been dropped or the enclosure damaged.

 CAUTION RISK OF ELECTRIC SHOCK DO NOT OPEN	To reduce the risk of electric shock, do not remove screws. No user-serviceable parts inside. Refer servicing to qualified service personnel. To reduce the risk of fire, electric shock or product damage, do not expose this apparatus to rain, moisture, dripping or splashing and that no objects filled with liquids, such as vases, shall be placed on the apparatus.
---	---



Table of contents

Before you start

Introduction.....	2
Features.....	2

Operation

Front and rear panels.....	3
----------------------------	---

Software interface

Connecting to device & navigating windows.....	4
Audio settings.....	5
System settings.....	8

Specifications

General specifications.....	10
-----------------------------	----

Before you start

DSP4X6 – 4 inputs and 6 outputs digital signal processor for line level audio signal processing and routing. Intuitive operation software gives easily understandable access to processing, as well as features factory presets for sound systems containing AMC RF series professional loudspeakers. Device perfectly fits small size audio installations to mix and route audio, split frequencies for two-way audio systems, adjust timing, add noise gate, set EQ or add audio limiter.

FEATURES

- Digital signal processor 4 x 6
- Balanced inputs and outputs
- 24 bit AD/DA converters
- 48 kHz sampling rate
- Gate, EQ, crossover, delay, limiter
- Type-B USB port to connect PC
- 10 preset memory
- Device booting preset

Operation

Front & rear panel functions

LED INDICATOR

LED indicator illuminates when device is ON. Switch device ON or OFF with the power switch on the back panel.

USB TYPE-B CABLE SOCKET

Connect your device with PC using type-B USB cable.

INPUT & OUTPUT CONNECTORS

Balanced Phoenix connectors for sound signal inputs and outputs. Use balanced sound cables.

MAINS POWER CONNECTOR

Connect device to mains power supply using provided power cable.

Front Panel

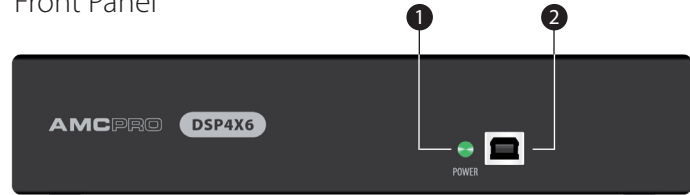

1. Power indicator LED | 2. USB type-B cable socket

Rear Panel

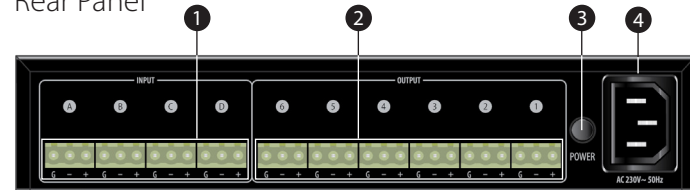

1. Balanced signal inputs | 2. Balanced signal outputs
3. Power switch | 4. Mains power connector

Software interface

Connecting to device & navigating windows

SOFTWARE DOWNLOAD

Visit www.amcpro.eu software & documents section to download the latest software for your device.

SYSTEM REQUIREMENTS

The software works with Windows XP / WIN7 / WIN8 / WIN10 x64 or x32 operating system, and can run directly from PC without installation.

CONNECTING TO DEVICE

Connect device to PC using USB type-B cable. Run the DSP46 software on the computer. The device will automatically connect to the computer within 3-5 seconds. The green "connected" indicator (1) will be displayed at the top of the window to indicate ongoing connection.

SWITCHING WINDOWS

The software has four main tabs for audio and device settings. Click on the tabs "Audio Setting" (2), X-over (3), Router (4) or "System Setting" (5) to switch window.

NAVIGATING SETTINGS

Click on the parameter to enter its setting window. The selected parameter will be highlighted with different colour.

The user interface follows signal patch starting with settings for each of 4 inputs, visually displayed input/output matrix (called Router) and finishes with 6 outputs and their dedicated settings.

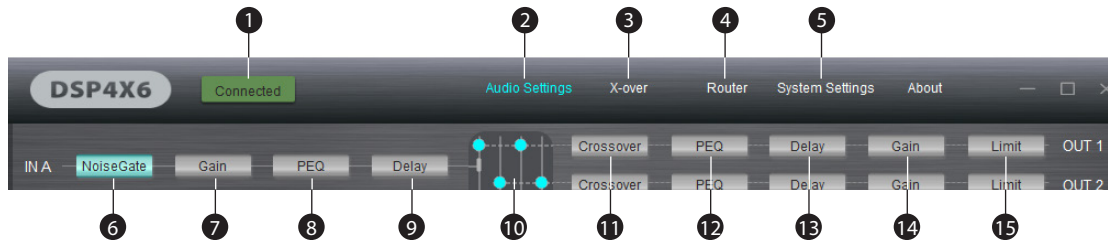

Software interface

Audio Settings

NOISE GATE (6)

Set the threshold level, attack and release time for channel input noise gate.



INPUT GAIN (7)

Set the signal input gain using the slider, or by entering specific value in dB. Here the channel can be muted or phase-inverted.

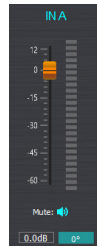

INPUT EQUALIZER (PEQ) (8)

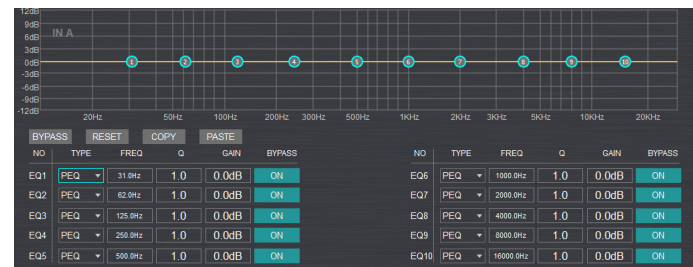

Input channels have separate 10-band equalizers. Each band can be set to act as parametric (PEQ), low or high shelf (LSLV / HSLV).

Click and hold left button on the highlighted circle with an EQ band number and drag it to set the frequency and gain. Each parameter can also be set by entering specific values in the chart. Each band can be individually bypassed.

BYPASS button mutes and unmutes all EQ bands at once.

RESET button restores all EQ settings to the default values.

COPY/PASTE buttons allow copying EQ settings from one input channel to another. Note: it is not possible to copy EQ settings from inputs to outputs.

Software interface

Audio Settings

INPUT DELAY (9)

Set a delay for each input channel. Delay range is 0.021-20 ms., value can also be entered in milliseconds, in centimetres or inches.



AUDIO ROUTER (4 & 10)

DSP4X6 provides flexible input-output matrix for signal routing. Each input channel can be assigned to any outputs, also each output channel can mix multiple inputs. Note: by default setting DSP4X6 inputs are routed as in the picture below.

		OUTPUT					
		OUT 1	OUT 2	OUT 3	OUT 4	OUT 5	OUT 6
INPUT	IN A	█	█	█	█	█	█
	IN B	█	█	█	█	█	█
	IN C	█	█	█	█	█	█
	IN D	█	█	█	█	█	█

CROSSOVER (11)

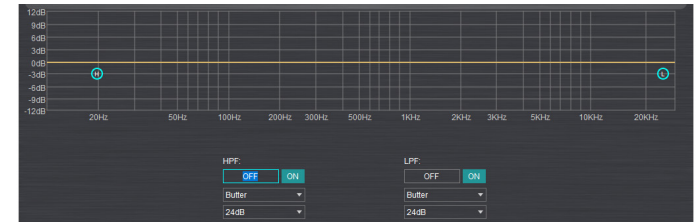

DSP4X6 can function as a crossover, with separate settings for each output. Set the high-pass and low-pass filters for each output by entering filter frequency, selecting roll-off curve shape and intensity from the list.

OUTPUT DELAY (13)

Set a delay for each output channel. Delay range is 0.021-20 ms., value can also be entered in milliseconds, in centimetres or inches.



Software interface

Audio Settings

OUTPUT EQUALIZER (12)

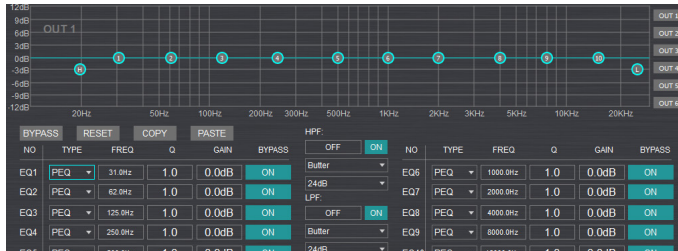

Output channels have separate 10-band equalizers. Each band can be set to act as parametric (PEQ), low or high shelf (LSLV / HSLV). Crossover settings are also displayed and can be changed in this window.

Click and hold left button on the highlighted circle with an EQ band number and drag it to set the frequency and gain. Each parameter can also be set by entering specific values in the chart. Each band can be individually bypassed.

BYPASS button mutes and unmutes all EQ bands at once.
 RESET button restores all EQ settings to the default values.
 COPY/PASTE buttons allow copying EQ settings from one input channel to another. Note: it is not possible to copy EQ settings from outputs to inputs.

OUTPUT GAIN (14)

Set the additional gain for output channel using the slider, or by entering specific value in dB. Here the output channel can be muted or phase-inverted.

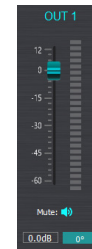

OUTPUT LIMITER (15)

Set a limiter for each output channel with a threshold fader or by entering a specific number in dB. Limiter release time has a range of 9-8686 ms.



Software interface

System Settings

HARDWARE MEMORY

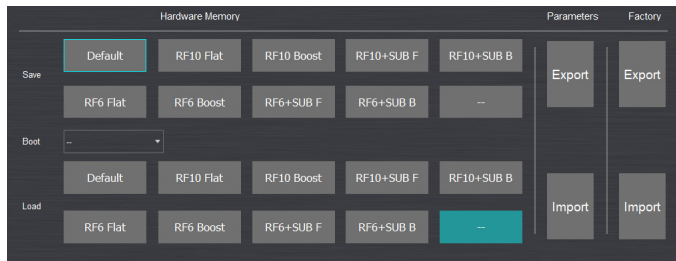

DSP4X6 can save 9 user defined presets in internal memory.

Click a preset button in the "Save" section to enter new preset name and save parameters.

Click a preset button in the "Load" section to restore saved parameters.

PARAMETERS: EXPORTING & IMPORTING

Current device parameters can be exported as a file to PC for future use or for easy configuration of multiple DSP4X6 devices.

Click "Export" button in the "Parameters" column to export a file, click "Import" to load file from PC.

FACTORY: EXPORTING & IMPORTING

All device presets can be exported as a single file to PC for future use or for easy configuration of multiple DSP4X6 devices.

Click "Export" button in the "Factory" column to export a file, click "Import" to load file from PC.

DEVICE BOOT PRESET

To select boot preset, select preset from drop-down list. Device will load selected preset every time it powers on.

Select "Last settings" from the preset list to boot device in the state it was when powering down.

Software interface

PRESETS FOR AMC RF PROFESSIONAL LOUSPEAKERS

By default DSP4X6 comes with pre-defined presets for various setups for AMC RF series professional loudspeakers.

Presets adjust PEQ and crossover settings for AMC loudspeakers RF 10, RF 6, and a subwoofer RFS 12. A "Flat" preset has a PEQ correction to flatten the loudspeaker audio frequency curve, while a "Boost" preset has a lift in a low-frequency range. All presets are for stereo setup and have the following input-output configurations:

Using only full range loudspeakers:

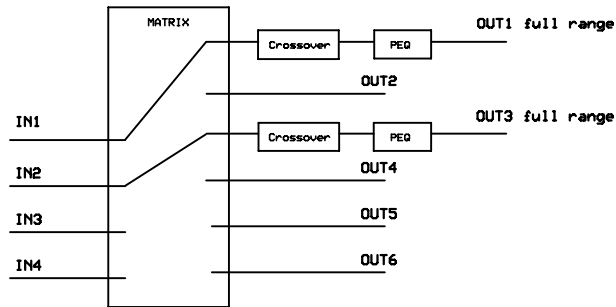

Using full range and subwoofer loudspeakers:

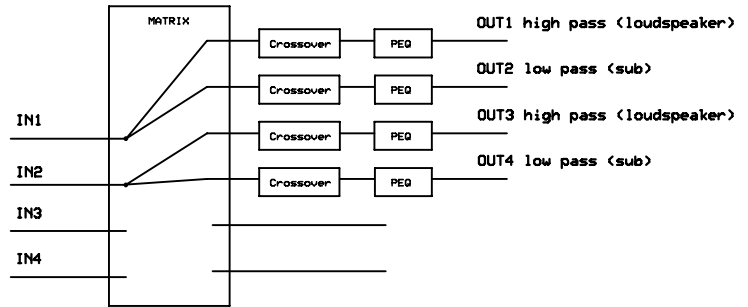

General Specifications

DSP4X6 Digital Signal Processor

Technical Specifications	DSP4X6
Power supply	~ 220-230 V, 50 Hz
Power consumption	11 W
Input / output connector	Balanced Phoenix
Input impedance	4,7 k Ω
Maximum input level	+8 dBu
Output impedance	100 Ω
Maximum output level	+10 dBu
Maximum gain	-28 dBu
Frequency response	20 Hz - 20 kHz
Distortion	<0.01% (0dBu/1kHz)
Dynamic range	100 dBu
Sampling rate	48 kHz
AD/DA converter	24 bit
Supported OS	Windows
Dimensions (H x W x D)	213 x 225 x 44 mm
Weight	1,38 kg

The specifications are correct at the time of printing this manual. For improvement purposes, all specifications for this unit, including design and appearance, are subject to change without prior notice.

