



# 2A Series

Amplifier



User Manual

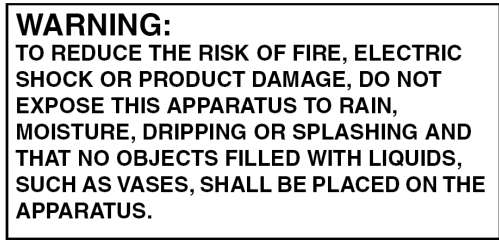
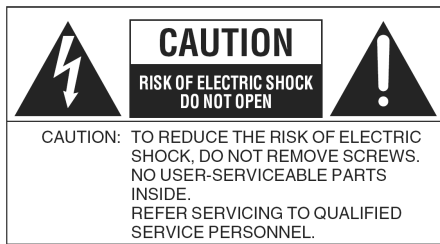

## IMPORTANT SAFETY INSTRUCTIONS

When using this electronic device, basic precautions should always be taken, including the following:

1. Read all instructions before using the product.
2. Do not use this product near water (e.g., near a bathtub, washbowl, kitchen sink, in a wet basement, or near a swimming pool.etc).
3. This product must be used with a rack or stand alone, when you are sure that the amplifier has a stable base.
5. This product, in combination with headphones or speakers, may be capable of producing sound levels that could cause permanent hearing loss. Do not operate for a long period of time at a high volume level or at a level that is uncomfortable. If you experience any hearing loss or ringing in the ears, you should consult an otorhinolaryngologists. The product should be positioned so that proper ventilation is maintained.
6. The product should be located away from heat sources such as radiators, heat vents, or other devices (including amplifiers) that produce heat.
7. The product should be connected to a power supply only of the type described in the operating instructions or as marked on the product. Replace the fuse only with one of the specified type, size, and correct rating.
8. The power supply cord should be undamaged and never share an outlet or extension cord with other devices so that the outlet's or extension cord's power rating is exceeded, and never be left plugged in to the outlet when not being used for a long period of time.
9. Care should be taken so that objects do not fall into, and liquids are not spilled through, the enclosure's openings.
10. The product should be serviced by qualified service personnel if:
  - The power supply cord or the plug has been damaged.
  - Objects have fallen into, or liquid has been spilled onto the product.
  - The product has been exposed to rain.
  - The product does not appear to operate normally or exhibits a marked change in performance.
  - The product has been dropped, or the enclosure damaged.
11. Do not attempt to service the product beyond what is described in the user maintenance instructions.

All other servicing should be referred to qualified service personnel.

## CONTENTS:

<u>Before you start</u>	
What's in the box	4
Features	4
Hints on installation	4
<u>Controls and connections</u>	
Front panel	5
Rear panel	6
Connections examples	7
<u>Specifications</u>	
Specifications	9

## 4 Before you start

Congratulations on your purchase stereo power amplifiers. This unit was developed using the expertise of professional sound engineers and working musicians. You will find that your new **2A Series** has superior performance and greater flexibility than any other amplifiers in its price range. Please read this manual carefully to get the most out of your new unit. Thanks for selecting **2A Series**.

### What's in the box?

Items those are included in the box:

- 2A Series amplifier
- Instruction manual
- Power cable

### Features

- Operating features: volume controls; balanced phoenix and XLR connectors, LINK output, compressor, input sensitivity selector, binding post and speakon output connectors, stereo/bridge/parallel mode, ground lift switch.
- Safety/reliability features: 2 variable speed fans for cooling, soft start, DC and thermal overload protection; short circuit and speaker protection.
- Indications: power ON, clip, signal, and protect LED indicators for each channel. Bridge and parallel indicators.
- Cabinet features: Roadworthy, rugged double rack space (2 U) housing. Direction of cooling air flow: from the rear to the front.

### Hints on Installation

This user manual contains important information on operating **2A series** amplifier correctly and safety. Please read it carefully before operating your amplifier.

#### INSPECTION

Your **2A Series** was carefully packed at the factory in packaging designed to protect the units in shipment. Before installing and using your unit, carefully examine the packaging and all contents for any signs of physical damage. If you find any damage, notify the shipping company immediately. Be sure to save the carton and all packing materials for carrier inspection.

#### RACK MOUNTING

The **2A Series** amplifiers are designed for standard 19" rack mounting as well as stand alone. Use 4 screws and washers for mounting to the front rack rails. It is also a good idea to support the amps in the rear, especially for mobile use where the amps will be subjected to strong vibrations.

#### AMPLIFIER COOLING

Also pay close attention to the cooling requirements. Never block the air vents in the back, side and front of the amplifier. Do not install the amplifier in a location that is exposed to direct rays of the sun or near the hot appliance or radiators. Installation of the amplifiers in a damp or dust environment may result in malfunction or accident. Please make sure to open the back doors, if installed in a rack. Periodically remove the internal dust by using compressed air through the external ventilation holes.

## Front Panel

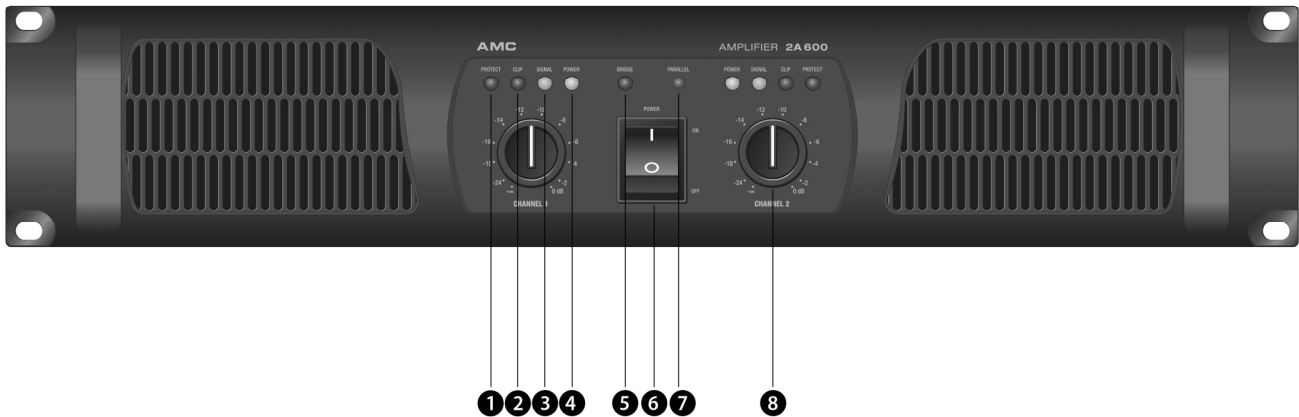
**1. PROTECT LED INDICATORS**

These LEDs illuminate if the power amplifiers output connection is shorted or the load impedance is too low. When either of these LEDs is lit up, turn OFF the power and check the output's connection to verify that it is correct, then turn ON the power again.

**2. CLIP LED INDICATORS**

These LEDs illuminate if any section of the power amplifier's output are clipping. Occasional blinking of the LEDs are acceptable, but if they remain on more than intermittently you should reduce the output level to avoid audible distortion.

**3. SIGNAL LED INDICATORS**

These LEDs illuminate to confirm the input signal greater than 100 mV at that channel of the amplifier.

**4. POWER LED INDICATORS**

These LEDs illuminate when the power is turned "ON".

**5. BRIDGE LED INDICATOR**

This LED illuminate when the amplifier is set in to bridge mode. In bridge mode Input2 is disabled, the input signal should be connected in to input1. Both channel volume controls are available. Please take attention in to loudspeakers connection diagram in the rear panel.

**6. POWER SWITCH**

To turn the unit ON or OFF, press this button. Before turning on the amplifier, check all connections and turn down the level controls. A momentary muting is normal when turning the amplifier on or off.

(Caution: Always turn on your power amplifier last, after all your other connected equipment, and always turn off your power amplifier before your other connected equipment.)

**7. PARALLEL LED INDICATOR**

This LED illuminate when the amplifier is set in to parallel mode. In parallel mode Input2 is disabled, the input signal should be connected to input 1. Both channel volume controls are available.

**8. LEVEL CONTROLS**

These knobs control the level of signal coming into each channel. The actual gain of the amplifier is shown in dB Scale. Turn these controls counter clockwise if the clip LEDs illuminate steadily. Set these knobs into the min position before turning on amplifier.

## Rear Panel

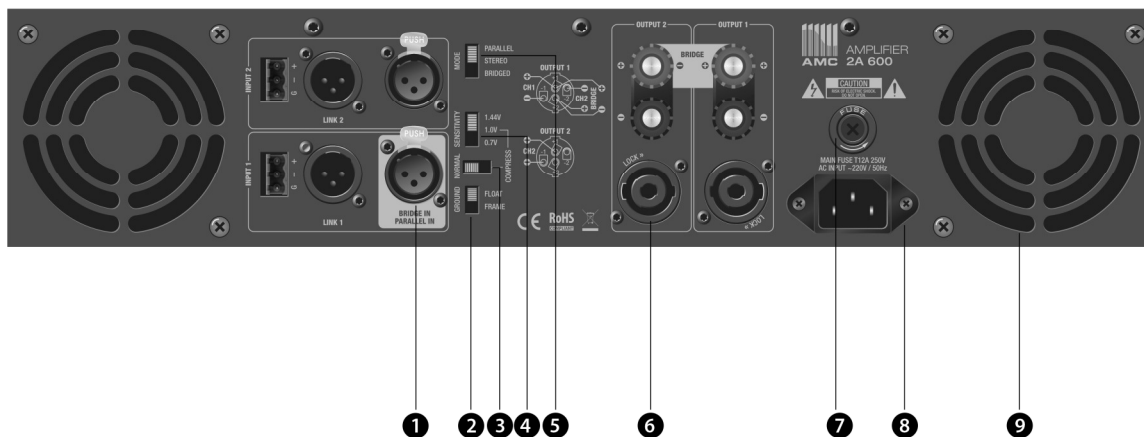
**1. INPUT CONNECTORS**

Connect your input signal to these balanced phono or XLR connectors. Link connector allows to have direct output from input connector.

**2. GND SWITCH**

To eliminate a ground loop, set ground switch to lift position and otherwise to connect a ground to amplifiers chassis.

**3. SENSITIVITY**

There are 3 level of input sensitivity 0.7V, 1V and 1,4V.

**4. COMPRESOR**

Set switch in to normal for disabling compressor. The compressor is active then 1V sensitivity is selected and switch is set to compressor.

**5. MODE SWITCH**

There are available 3 modes of operation: stereo, bridge and parallel. Don't use this switch then amplifier is turning on.

*Stereo mode:* This is general used mode. In this mode both inputs require audio signal and both volume controls are active. In stereo mode Channel 1 and Channel 2 work independently. The minimum loudspeakers impedance should be no less then  $2\Omega$ .

*Bridge mode:* This mode combines the power from both channels to drive a single loudspeaker. In this mode only input1 require audio signal but both volume controls are

active. The minimum loudspeakers impedance should be no less then  $4\Omega$ . Please note that prolonged outputs overdriven can be reason of main fuse blowing.

*Parallel mode:* This mode allow both channels to operate in parallel with same signal. In this mode the inputs for both channels are internally connected, so only input1 require audio signal but both volume controls are active. Do not use parallel mode then feeding the amplifier with two separate signals. Please note that only amplifier inputs are connected in parallel. Do not connect positive and negative output connectors in parallel! This is not a output parallel mode.

**6. OUTPUT CONNECTORS**

4 pole Speakon and blinding post connectors.

**7. MAIN FUSE**

For continued protection against risk of fire, replays only same type fuse. If fuse continuously blowing, contact with qualified service personnel.

**8. MAIN POWER**

Main power socket.  $\sim 220V$  50Hz.

**9. VENTILATION HOLES**

The fan speed is varied automatically to maintain the proper internal operating temperature. Direction of cooling air flow: from the rear to the front.

## Connections examples

## STEREO SYSTEM (stereo mode)

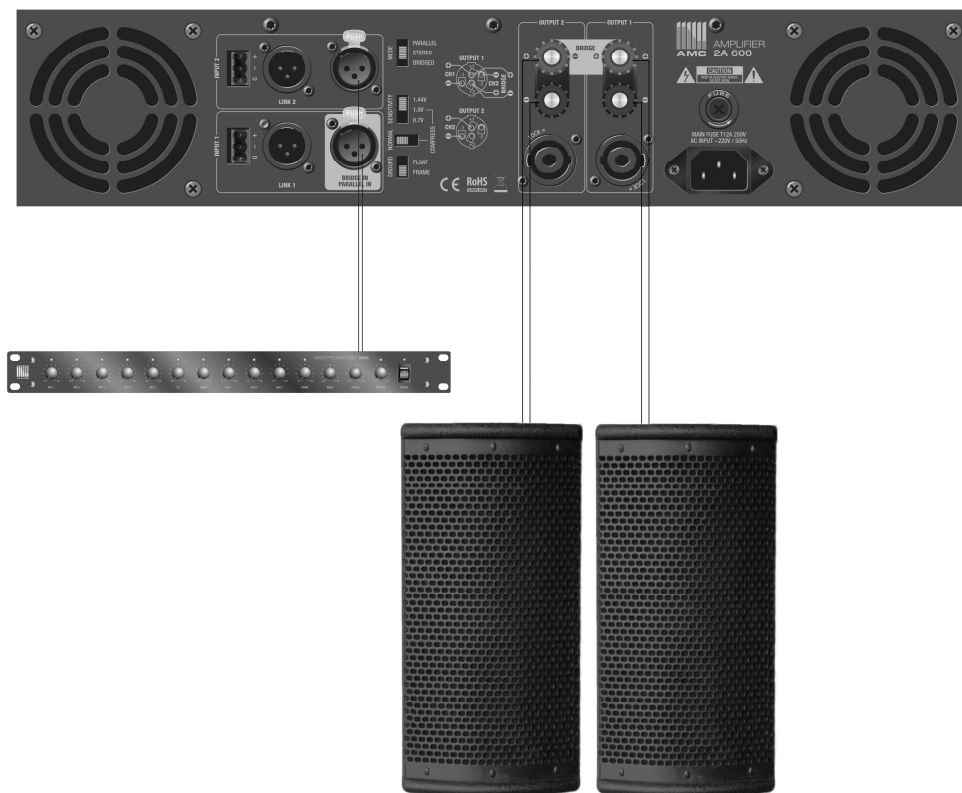

## MONO SYSTEM (parallel mode)

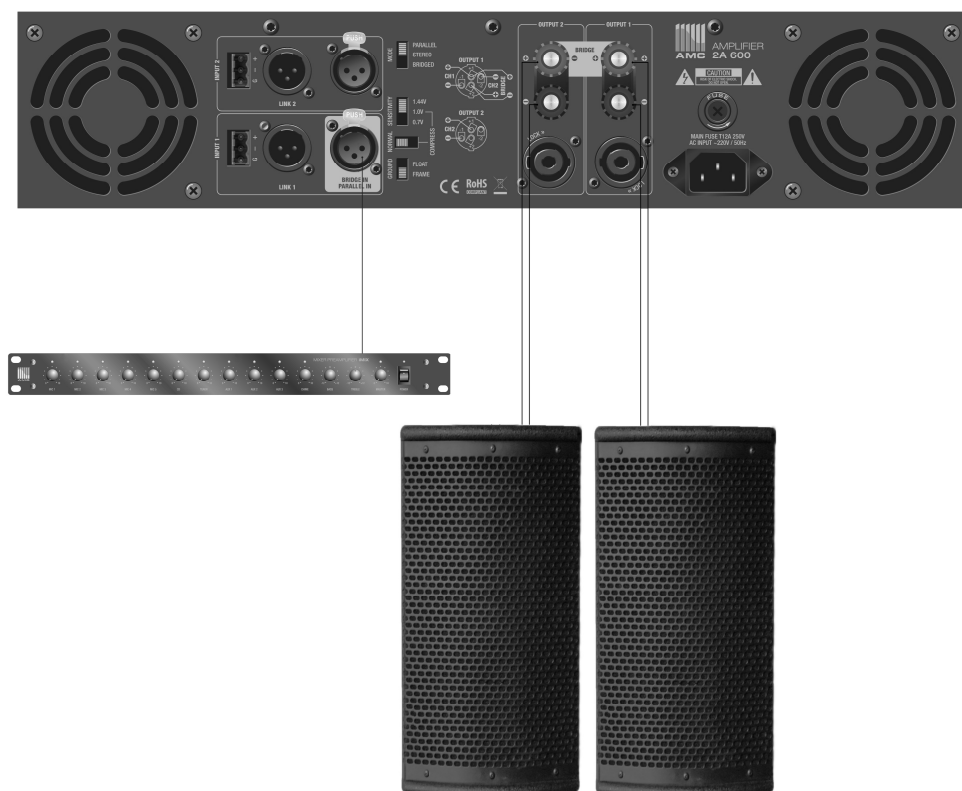

MONO SYSTEM (Bridge mode)

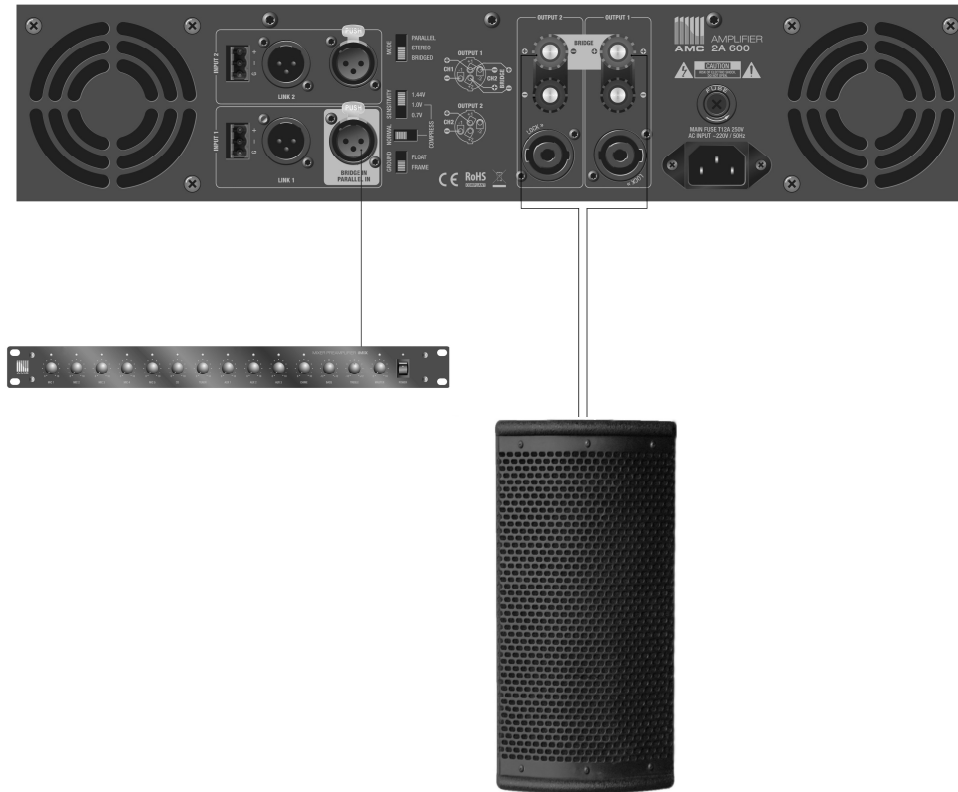

Block diagram

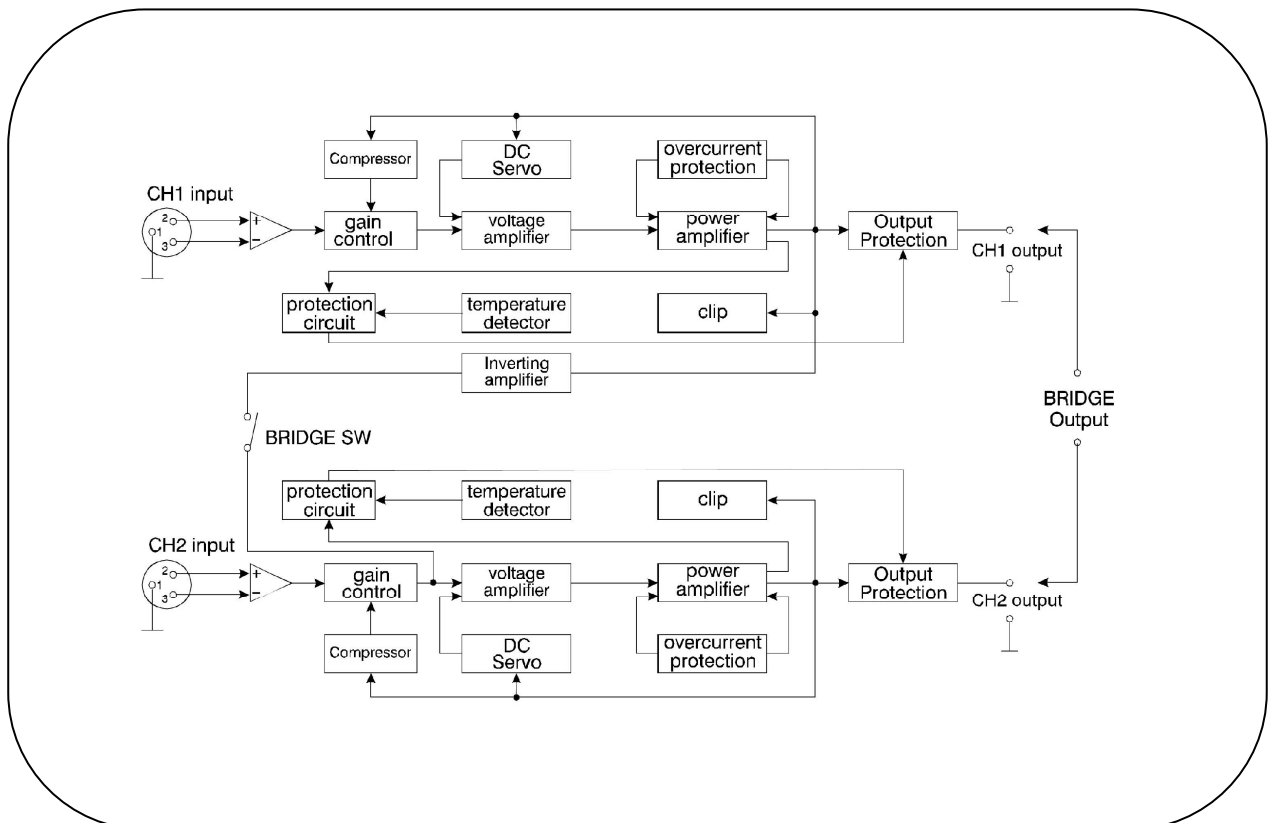



## Specifications

<b>Power specifications</b>	<b>2A400</b>	<b>2A600</b>
Rated output power (8 $\Omega$ ) (Stereo mode)	2x400W	2x600W
Rated output power (4 $\Omega$ ) (Stereo mode)	2x700W	2x1050W
Rated output power (8 $\Omega$ ) (Bridge mode)	1250W	1750W
Rated output power (4 $\Omega$ ) (Bridge mode)	1700W	2300W
Input Sensitivity	0.775 V (0 dBu)/ 1.0 V (2.2dBu)/ 1.44 V (5.3 dBu)	
Input Impedance	10k $\Omega$ unbalanced	
Frequency Response	15 Hz - 25 kHz: $\pm 1$ dB	
Distortion THD+noise 1kHz in full power	< 0.03%	< 0.035%
Signal to Noise Ratio	> 102dB	> 105dB
Slew rate	40V/ $\mu$ S	
Damping Factor (1 kHz @ 8 $\Omega$ )	> 400 :1	
<b>General specifications</b>		
Amplifier Protection	Full short circuit, open circuit, thermal, soft start, DC voltage.	
Amplifiers class	AB	
Controls	Front: AC switch, channel 1 & 2 volume knobs	
Indicators	Power-on, signal, clip, protect, bridge, parallel	
Connectors (each channel)	Input: balanced Phoenix and XLR Output: Speakon, blinding post.	
Power Requirements	~230V AC 50Hz	
Fuses	T8A/250V	T12A/250V
Dimensions (HxWxD)	89x482x453mm	
Weight - Net	22.5 kg	25 kg

*The specifications above are correct at the time of printing of this manual. For improvement purposes, all specifications for this unit, including design and appearance, are subject to change without prior notice.*

